

Planetary Mixers
Planetary Mixer, 8 lt. - Electronic
with Hub

ITEM # _____

MODEL # _____

NAME # _____

SIS # _____

AIA # _____



600196 (BE8BYA)

* NOT TRANSLATED *

Main Features

- Professional compact table top beater mixer for intensive kneading, mixing and whipping.
- Maximum capacity 2.5 kg flour, with 60% of hydration.
- Delivered with: Spiral Hook, Paddle, Wire Whisk and Mixing Bowl for 8 lt. All made in stainless steel and dishwasher safe.
- Tools shape and size perfectly adapt to the bowl for uniform mixing of even small quantities.
- Electronic speed variator.
- Safety device will automatically stop the machine when the bowl is lowered.
- Ergonomic and reliable knob to select the speed adjusting to the tool and mixture hardness.
- Removable safety screen activates the raising and lowering of the bowl.
- Bowl detection device allows the mixer to switch on only when the bowl and the solid safety screen are properly installed and positioned together.

Construction

- 304 AISI stainless steel 2 handles bowl - 8 lt. capacity.
- Compact and portable design.
- Asynchronous motor with high start-up torque.
- Variable speed from 20 to 220 rpm (planetary movement), to adjust to the selected tool and mixture hardness.
- Planetary movement based on self lubricating gears, eliminating any risk of leaks.
- Water protected planetary system (IP55 electrical controls, IP34 appliance overall).
- Transparent solid safety screen made of Eastman Tritan™ copolyester BPA free, impact resistant and stays clear and durable after several dishwashing cycle.
Eastman&Tritan are trademarks for Eastman Chemical Company.
- Variable speed rotation of the tools from 67 rpm to 740 rpm.
- Sturdy metal accessory hub able to withstand heavy usage.

APPROVAL: _____

Included Accessories

- 1 of Additional stainless steel bowl 8 lt PNC 653766
- 1 of Additional stainless steel spiral hook 8 lt PNC 653767
- 1 of Additional stainless steel paddle 8 lt PNC 653768
- 1 of Additional stainless steel whisk 8 lt PNC 653769

Optional Accessories

- 60 mm meatmincer for attachment type K (12 mm square hub) and 1 disc PNC 653043
- 3 discs (3-4,5-8 mm) for meatmincer PNC 653044
- - NOT TRANSLATED - PNC 653296
- - NOT TRANSLATED - PNC 653298
- - NOT TRANSLATED - PNC 653300
- Additional stainless steel bowl 8 lt PNC 653766
- Additional stainless steel spiral hook 8 lt PNC 653767
- Additional stainless steel paddle 8 lt PNC 653768
- Additional stainless steel whisk 8 lt PNC 653769
- Closed splash guard for BE5/8 with accessory hub PNC 653782

Front

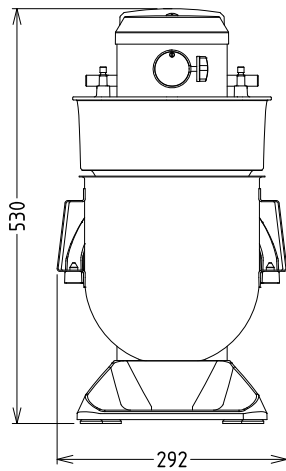

Electric

Supply voltage: 200-240 V/1N ph/50/60 Hz
 Electrical power max.: 0.6 kW

Capacity:

Performance (up to): 2.5 kg/Cycle
 Capacity: 8 litres

Key Information:

External dimensions, Width: 292 mm
 External dimensions, Depth: 416 mm
 External dimensions, Height: 527 mm
 Shipping weight: 21 kg
 Net weight (kg): 19
 Cold water paste: 2.5 kg with Spiral hook
 Egg whites: 14 with Whisk

Side

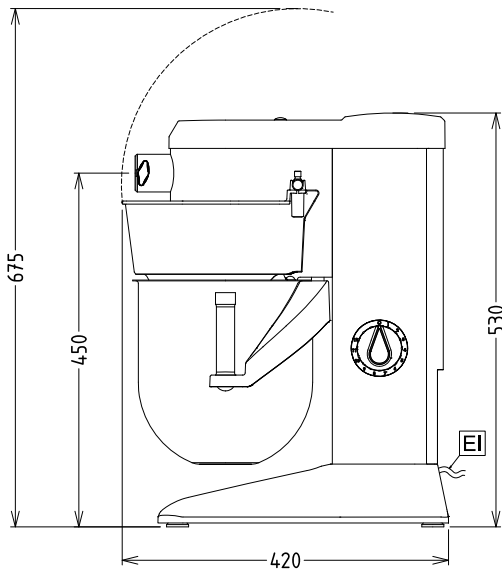

EI = Electrical inlet (power)

Top

